

4

3

2

1

B

B

A

A

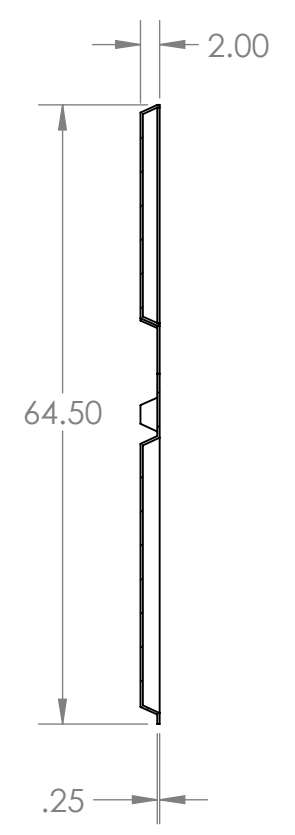
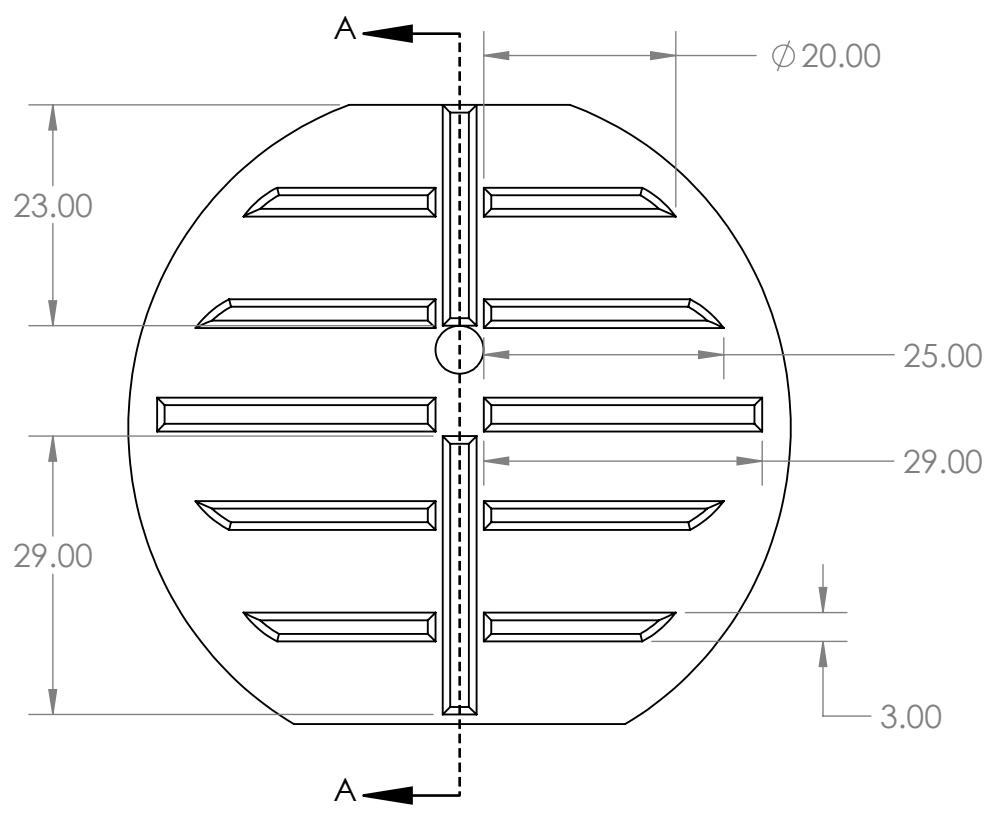

SECTION A-A

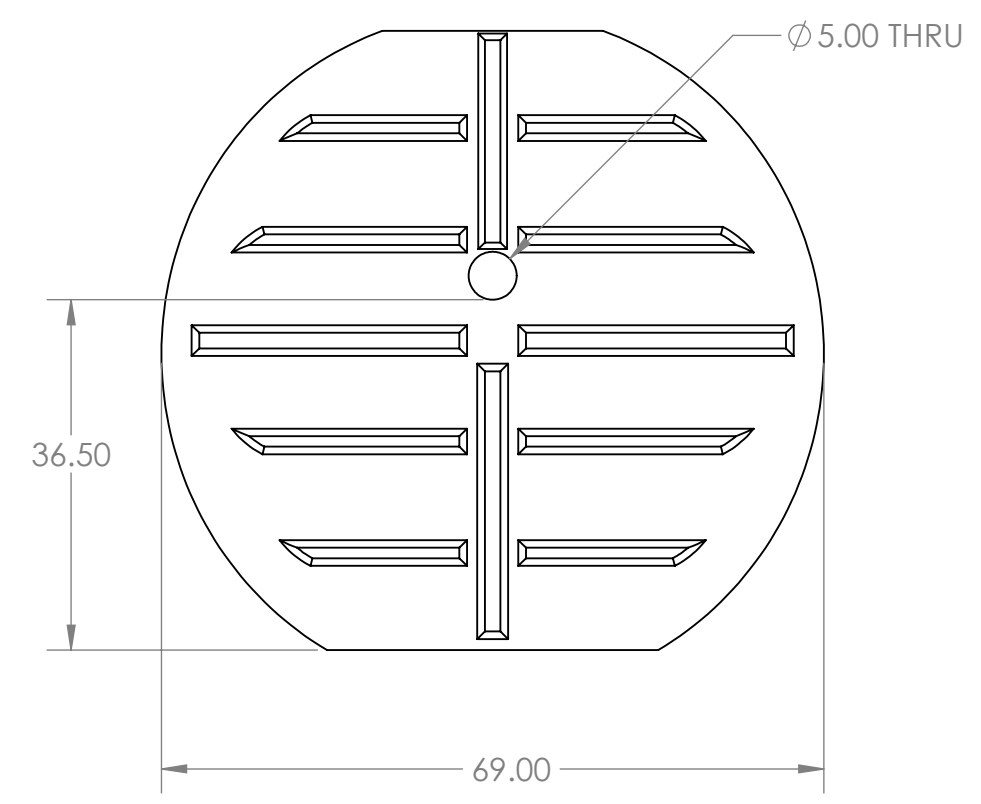

**PROPRIETARY AND CONFIDENTIAL**  
 THE INFORMATION CONTAINED IN THIS DRAWING IS THE SOLE PROPERTY OF <INSERT COMPANY NAME HERE>. ANY REPRODUCTION IN PART OR AS A WHOLE WITHOUT THE WRITTEN PERMISSION OF <INSERT COMPANY NAME HERE> IS PROHIBITED.

		UNLESS OTHERWISE SPECIFIED:	NAME	DATE				
		DIMENSIONS ARE IN INCHES	DRAWN					
		TOLERANCES:	CHECKED		TITLE:			
		FRACTIONAL ±	ENG APPR.					
		ANGULAR: MACH ± BEND ±	MFG APPR.					
		TWO PLACE DECIMAL ±	Q.A.					
		THREE PLACE DECIMAL ±	COMMENTS:					
		INTERPRET GEOMETRIC TOLERANCING PER:				SIZE	DWG. NO.	REV
		MATERIAL				<b>B</b>	<b>900 Baffle</b>	
NEXT ASSY	USED ON	FINISH				SCALE: 1:20	WEIGHT:	SHEET 1 OF 1
APPLICATION		DO NOT SCALE DRAWING						

4

3

2

1