

4

3

2

1

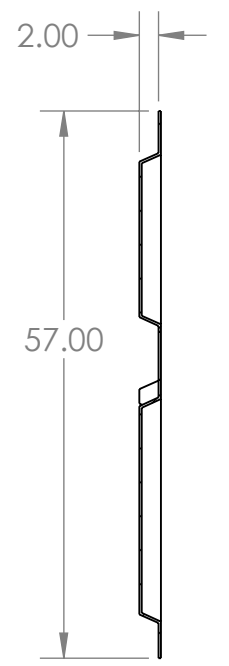
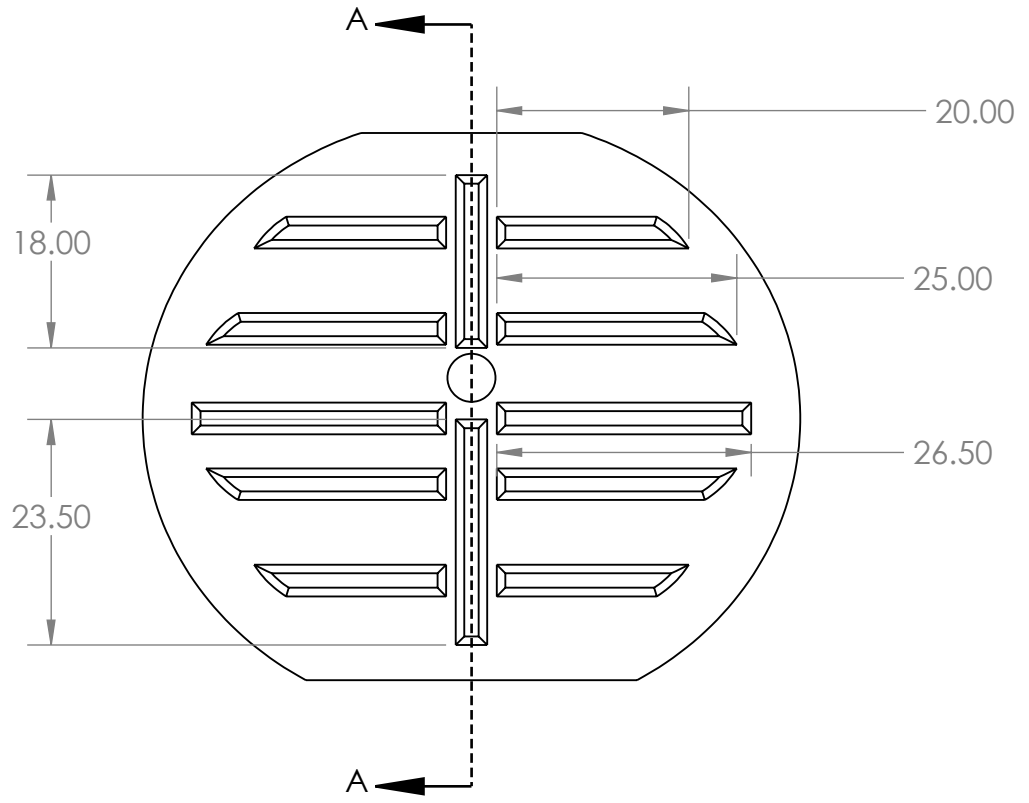

SECTION A-A

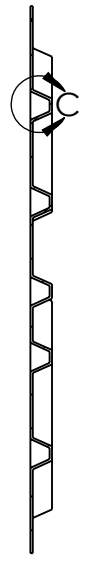
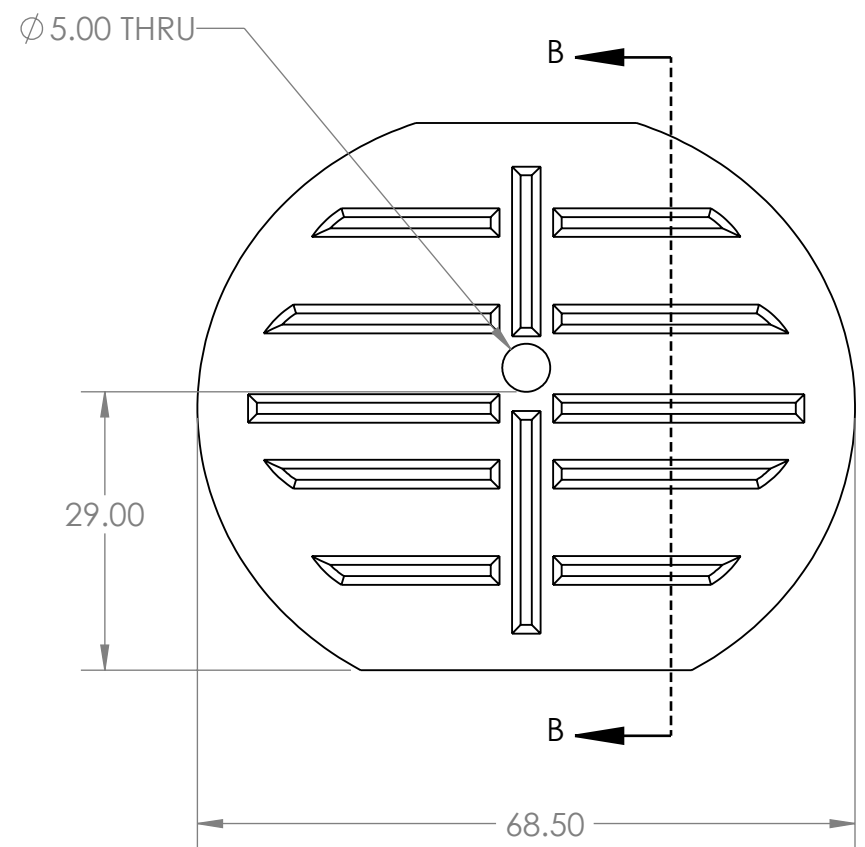

SECTION B-B

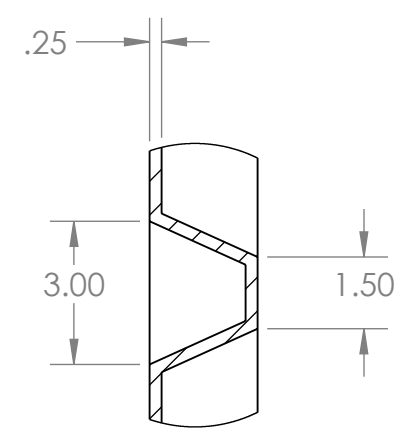

DETAIL C
SCALE 1 : 4

PROPRIETARY AND CONFIDENTIAL
 THE INFORMATION CONTAINED IN THIS DRAWING IS THE SOLE PROPERTY OF <INSERT COMPANY NAME HERE>. ANY REPRODUCTION IN PART OR AS A WHOLE WITHOUT THE WRITTEN PERMISSION OF <INSERT COMPANY NAME HERE> IS PROHIBITED.

		UNLESS OTHERWISE SPECIFIED:		NAME	DATE		
		DIMENSIONS ARE IN INCHES	DRAWN			TITLE:	
		TOLERANCES:	CHECKED				
		FRACTIONAL \pm	ENG APPR.				
		ANGULAR: MACH \pm BEND \pm	MFG APPR.				
		TWO PLACE DECIMAL \pm	Q.A.				
		THREE PLACE DECIMAL \pm	COMMENTS:				
		INTERPRET GEOMETRIC TOLERANCING PER:				SIZE	DWG. NO.
		MATERIAL				B	750 Baffle
		FINISH				SCALE: 1:20	WEIGHT:
NEXT ASSY	USED ON	DO NOT SCALE DRAWING				REV	SHEET 1 OF 1
APPLICATION							

4

3

2

1

B

B

A

A